



Taguchi Method for Development of Mass Flow Rate Correlation using Hydrocarbon Refrigerant Mixture in Capillary Tube

Shodiya Sulaimon^{1, 2}, Henry Nasution^{1*}, Azhar Abdul Aziz¹,
Abdul-Halim Abdul-Rahman¹ & Amer N. Darus¹

¹Automotive Development Centre, Faculty of Mechanical Engineering
Universiti Teknologi Malaysia, Skudai, Johor, 81310, Malaysia

²Department of Mechanical Engineering, Faculty of Engineering,
University of Maiduguri (UNIMAID), P.M.B 1069, Maiduguri, Borno State, Nigeria

*Email: henry@fkm.utm.my

Abstract. The capillary tube is an important control device used in small vapor compression refrigeration systems such as window air-conditioners, household refrigerators and freezers. This paper develops a non-dimensional correlation based on the test results of the adiabatic capillary tube for the mass flow rate through the tube using a hydrocarbon refrigerant mixture of 89.3% propane and 10.7% butane (HCM). The Taguchi method, a statistical experimental design approach, was employed. This approach explores the economic benefit that lies in studies of this nature, where only a small number of experiments are required and yet valid results are obtained. Considering the effects of the capillary tube geometry and the inlet condition of the tube, dimensionless parameters were chosen. The new correlation was also based on the Buckingham Pi theorem. This correlation predicts 86.67% of the present experimental data within a relative deviation of -10% to +10%. The predictions by this correlation were also compared with results in published literature.

Keywords: *capillary tube; correlation; statistical experimental design; hydrocarbon refrigerant; vapor compression refrigeration.*

1 Introduction

A capillary tube is a small bore tube used as expansion and metering device in small vapor compression refrigeration systems such as household refrigerators and air-conditioners. The capillary tube offers quite a number of advantages over other expansion devices such as thermostatic and thermocouple expansion devices, for example, it is simple, inexpensive and requires only a low starting torque for the compressor [1].

As a result of environmental politics, evaluation of each component of the refrigeration and air-conditioning (R&A) system is necessary, most especially, the use of alternative refrigerant in the capillary tube. For optimum performance

Received December 4th, 2012, 1st Revision September 18th, 2013, 2nd Revision November 22nd, 2013, 3rd Revision January 16th, 2014, Accepted for publication February 4th, 2014.

Copyright © 2014 Published by ITB Journal Publisher, ISSN: 2337-5779, DOI: 10.5614/j.eng.technol.sci.2014.46.2.2

of the system, using the proper size of capillary tube with the new refrigerants is important.

The design and performance of adiabatic capillary tubes using chlorofluorocarbon (CFC)s, hydrochlorofluorocarbon (HCFC)s and hydrofluorocarbon (HFC)s as refrigerants have been studied extensively [2]-[6]. Replacing the CFCs and HCFCs with HFCs is a typical example of an industry switching from one harmful chemical to another. By shifting to HCFCs since the ban of CFCs, there has been a continuous destruction of the ozone layer and it has also tarnished the legacy of the Montreal Protocol [7] by creating enormous and unnecessary climate problems. In reaction to these problems and in search for a long-term solution, attention has been drawn to a natural solution, hydrocarbon (HC) refrigerants and their mixtures. HC refrigerants are proffered as substitute refrigerants since they have zero ozone depletion potential (ODP) due to the absence of chlorine atoms; they have low global warming potential (GWP); they are non-toxic; they provide a higher performance compared with other refrigerant types; and they are highly miscible with mineral oil [8].

The change from conventional refrigerants to natural refrigerants will be more attractive if this transformation does not require a major modification in the R&A system. Unfortunately, the thermophysical and thermodynamic properties of the conventional refrigerants are different from most of the natural HC refrigerants. For instance, the saturation pressure of propane (HC290) at a given temperature is higher than that of most of the conventional refrigerants, where that of butane (HC600) and iso-butane (HC600a) is lower [9]. For this reason, a more practical solution would be a mixture of HC refrigerants that has properties closer to a synthetic refrigerant rather than a pure HC refrigerant. Wongwises, *et al.* [10] investigated the behavior of HC refrigerant mixtures of HC290, HC600 and HC600a in an automotive air-conditioning (AC) system originally designed to use refrigerant R134a as a working fluid. They concluded that all the HC mixtures yielded a COP higher than that of R134a. Nasution [11] conducted an experiment using a mixture of HC refrigerants HC290/HC600/HC600a on a split-type AC system. The AC system was originally designed to use HCFC22. The results showed that the COP of the HC mixture was higher than that of HCFC22 by 9% and it saved about 16% energy consumption.

In order to adopt environmentally safe refrigerants at a reasonable cost, which require no major changes in the system, many research works have been carried out, as listed above. These researches focused on the whole R&A system. However, Fatouh [12] carried out a theoretical investigation on adiabatic capillary tubes using propane/n-butane/iso-butane blends as working fluid. His

results showed that the ratios of the average mass flow rate of the HC blend, having 0.6 propane mass fraction, to that of CFC12 and HFC134a were approximately 0.62 and 0.67 respectively. Nevertheless, experimental studies on capillary tubes using HC refrigerants in the R&A system are scarce. In fact, the existing correlations are not suitable for designing capillary tubes that use HC refrigerants because they (the correlations) are based on conventional refrigerants. Thus, the objective of the present study is to develop a generalized correlation for predicting the refrigerant mass flow rate through an adiabatic capillary tube with an HCM refrigerant (89.3% butane and 10.7% propane) using the Taguchi experimental design approach.

2 Experiment

2.1 Experimental setup

A schematic diagram of the experimental apparatus used to study the performance behavior of an HCM refrigerant in an adiabatic capillary tube used in a small vapor compression refrigeration system is shown in Figure 1. This test rig was designed for easy control of the operating parameters, namely, condenser temperature, degree of subcooling, capillary tube inner diameter and capillary tube length. The test rig was made up of a pressure regulator, electric bulb box, insulated room with electric bulb, four heat exchangers of different sizes, a refrigerant receiver, a mass flow meter and capillary tubes of ten different sizes. The valves were used to select the components included in the experiment. The direction of the flow of the refrigerant around the test rig is shown in the figure with arrows.

The condenser temperature was varied and stabilized using electric lamps located behind the condenser. The pressure regulator was adjusted to control the pressure inlet of the capillary tube to the corresponding condenser temperature. The heat exchanger was used to vary the degree of subcooling and the receiver supplied the subcooled refrigerant to the inlet capillary tube. The mass flow rate was monitored with a mass flow meter with an accuracy of $\pm 0.5\%$, which was fixed between the receiver and the capillary tube inlet. Both the inlet and exit pressure of the capillary tube were monitored through a pressure transducer and the results were displayed on the screen and recorded manually. Likewise, these pressures were also monitored by installing bourdon tube master pressure gauges with an accuracy of $\pm 0.5\%$ of full scale at the inlet and exit of the test sections. Two K-type thermocouples with an accuracy of $\pm 0.1^\circ\text{C}$ were installed at the inlet and exit of the test section to monitor the temperature of the refrigerant.

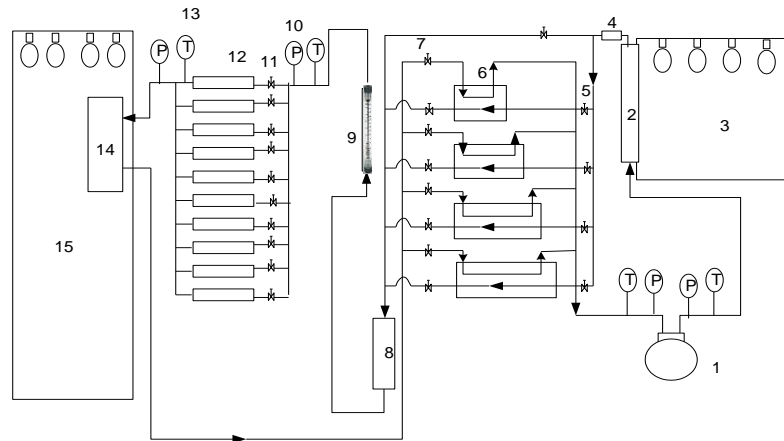

1. Compressor, 2. Condenser, 3. Bulb box, 4. Filter drier, 5. High pressure valves, 6. Heat exchangers, 7. Low pressure valve, 8. Receiver, 9. Flow meter, 10. Pressure transducer, 11. Hand valve, 12. Capillary tubes, 13. Thermocouple, 14. Evaporator, 15. Insulated Room

Figure 1 Schematic diagram of the experimental set-up.

2.2 Experimental Conditions

In this study, HCM refrigerant and capillary tubes of ten different sizes made of copper were used. The capillary tube sizes were selected due to their popularity in the market and also to have easy variation of the capillary tube geometry in terms of length and diameter. In order to select the capillary tube to be included in the test circuit, suitable valves were used. The capillary tubes were attached tightly to a header. The experimental conditions were carefully selected based on typical operating conditions of a split-type air conditioning system. For each of the condensing temperatures (34, 38, 40 and 42°C) the inlet pressure was carefully adjusted to their corresponding saturated conditions. Degrees of subcooling of 1.5, 4.5, 7.5, and 13.5°C were considered at the capillary tube inlet. The exit pressures of the capillary tube were maintained at a typical range for a split-type air conditioning system corresponding to an evaporating temperature range of 7 to 15°C.

2.3 Experimental Procedure

The original components of the refrigeration system from the manufacturer were used for the first run of the experiment. When the refrigeration system was on, refrigerant was filled into the system until it attained a stable condition. It takes about 45 minutes to achieve this condition. Thereafter, to start the actual experiment and to obtain the desired condenser temperature, some of the electric bulbs in the bulb box at the condenser were turned on. The appropriate

valves of the heat exchanger were open for a degree of subcooling. Then, the inlet pressure was adjusted using the pressure regulator to the pressure corresponding to the condenser temperature. Thus, the valve of the capillary tube was opened for the refrigerant to expand across it. The low-temperature and low-pressure two-phase refrigerant exiting the capillary tube entered the evaporator, where it absorbed heat and then entered the heat exchanger. The refrigerant now entered the compressor from the heat exchanger to repeat the cycle. During the experiment, while changing the degree of subcooling, adjustment of the inlet pressure to the predetermined values was very difficult to achieve. As a result, the value of the mass flow rate was taken (that is, the system was assumed to have attained a steady state) when the variation of the temperature and pressure were within $\pm 1.0^\circ\text{C}$ and $\pm 0.15\text{MPa}$ respectively. The thermodynamic properties of the refrigerant were taken from the REFPROP computer program, version 8 (2007).

2.4 Taguchi Experimental Design

The Taguchi experimental design is an important means of designing a robust experiment. This method will show in its analysis which of the factors will be more effective to achieve the desired goals and also the factors that need to be adjusted for improvement [13].

In performing the experiment that was used for the development of the mass flow rate correlation, all four parameters, namely, condenser temperature, degree of subcooling, capillary tube length and capillary tube inner diameter, were varied over four levels to form the L_{16} orthogonal array [13]. Table 1 shows the experimental variables and levels.

By applying these variables at the specified levels to the L_{16} orthogonal array of the Taguchi method using the Design Expert software application (version 7.1, Stat-Ease, Inc., Minneapolis, USA), the software generated the experimental conditions that were performed.

Table 1 Experimental variables and levels.

Variables	Level			
	1	2	3	4
Condenser temp., T_{cond} . ($^\circ\text{C}$)	34	38	40	42
Degree of subcooling, T_{sub} . ($^\circ\text{C}$)	1.5	4.5	7.5	13.5
Length of capillary tube, L (m)	0.55	1.05	1.30	1.55
Diameter of capillary tube, D (mm)	1.374	1.629	1.629	1.752

2.5 Development of Correlation

The design factors that are significant to the capillary tube flow rate are: the geometric factors – capillary tube inner diameter (D), capillary tube length (L), the operational factors – condenser temperature ($T_{cond.}$) and degree of inlet subcooling ($T_{sub.}$), and the fluid properties – viscosity (μ), surface tension (σ), specific heat (C_{pf}), specific volume (v) and heat of vaporization (C_{pf}). In the operational factors, the exit pressure of the capillary tube was not considered because a choked flow condition is always achieved at steady state of the system [14]-[16]. Accordingly, the mass flow rate could be determined as a function of all these variables, as shown in Eq. (1).

$$m = f[(P_{in} - P_{sat}), T_{sub}, L, D, v_f, v_g, \mu_f, \mu_g, \sigma, h_{fg}, C_{pf}] \quad (1)$$

Based on the Buckingham Pi theorem, analysis of all the variables in Eq. (1) with four repeating variables D, v_f, μ_f and C_{pf} [17-19] gives eight non-dimensional Pi groups. In Eq. (1), the total number of factors is twelve (a=12) and there are four repeating variables (b=4). Therefore, according to the Buckingham Pi theorem, in order to get the dimensionless parameters, the number of repeating variables (b) is subtracted from the physical parameters (a), that is, a-b=8. As a result, eight Pi-terms were derived using dimensional analysis. The results are shown in Table 2.

Table 2 Dimensionless Pi-terms.

Pi-group	Definition	Effect
π_1	$m/D\mu_f$	Mass flow rate
π_2	L/D	Tube geometry
π_3	μ_g/μ_f	Viscous, bubble growth
π_4	v_g/v_f	Density effect
π_5	$D\sigma/v_f\mu_f^2$	Surface tension, bubble formation
π_6	$D^2h_{fg}/v_f^2\mu_f^2$	Heat of vaporization
π_7	$D^2C_{pf}\Delta T_{sub.}/v_f^2\mu_f^2$	Inlet subcooling
π_8	$D^2(P_{in} - P_{sat})/v_f\mu_f^2$	Inlet pressure

The dimensionless parameters below (Table 2) were used to develop the correlation using a power law form with π_1 , mass flow rate term between dependent variables and other π s the independent variables. Eq. (2) shows the form of this relationship.

$$\pi_1 = a\pi_2^b\pi_3^c\pi_4^d\pi_5^e\pi_6^f\pi_7^g\pi_8^h \quad (2)$$

The Excel Solver tool was used to determine the exponents and constants of the Pi terms using a non-linear regression analysis on the measured data. It is possible to predict the refrigerant mass flow rates by solving Eq. (2) for flow rate in the π_1 term. The developed correlation is given in Eq. (3).

$$\pi_1 = 1.1378\pi_2^{-0.1347}\pi_3^{-0.6011}\pi_4^{-0.0253}\pi_5^{-0.5429}\pi_6^{0.1097}\pi_7^{0.0261}\pi_8^{0.0520} \quad (3)$$

3 Results and Discussion

The generalized correlation that was developed using HCM refrigerant was used for predicting the flow rate of the HCM refrigerants, as shown in Figure 2. For all the test conditions, approximately 86.67% of the experimental data points of HCM were within $\pm 10\%$ deviation. Furthermore, the correlation was also in good agreement with the experimental data points, with an average deviation (AD) and standard deviation (SD) of -0.14% and 11.77% respectively.

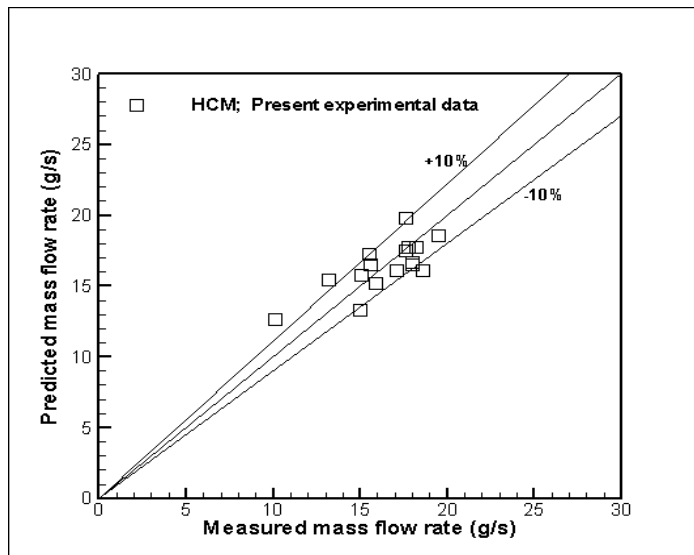

Figure 2 Comparison between flow rate predicted from generalized correlation and HCM measured data.

Again, in order to expand the application limit of the present generalized correlation model (Eq. (3)) imposed by the data used, the correlation model was used to predict the experimentally measured mass flow rate from Jabaraj, *et al.* [17] for a refrigerant mixture of HFC407C/HC600a/HC290 (M20), and a hydrocarbon mixture with HFC407C. A comparison of the predicted flow rate and the experimental data is depicted in Figure 3. Thus, the present correlation predicts about 73.33% of the measured data within a deviation of $\pm 10\%$.

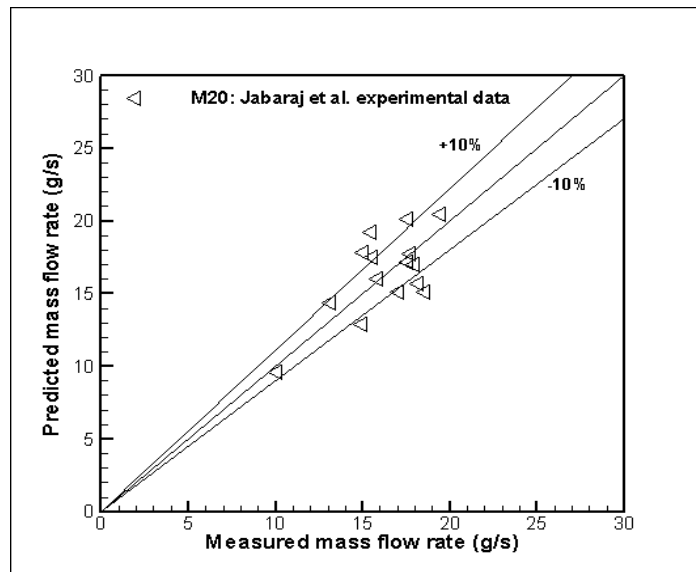

Figure 3 Comparison of mass flow rate predicted with measured data from Jabaraj, *et al.* [17] with M20 refrigerant.

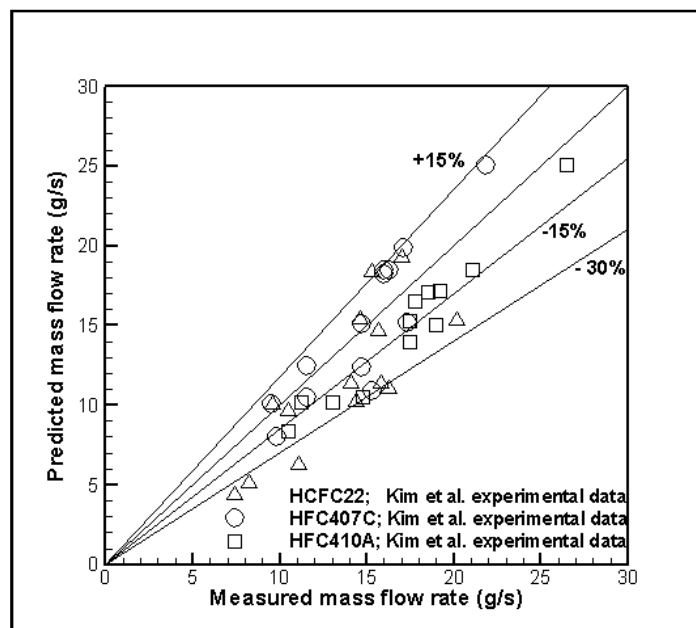

Figure 4 Comparison of mass flow rate predicted with measured data from Kim, *et al.* [16].

The integrity of the present correlation model was further assessed by comparing the predicted mass flow rate with experimentally measured data from Kim, *et al.* [16] for HCFC22, HFC410A and HFC407C refrigerants. As can be seen in Figure 4, the correlation predicted approximately 53.84%, 74.92% and 88.46% of the experimental mass flow rate of HCFC22, HFC410A and HFC407C respectively, within a deviation of -15% to +15%. Also, the correlation predicted about 80.72%, 98.62%, and 96.32% of the measured mass flow rate of HCFC22, HFC410A and HFC407C respectively, within a deviation of -30% to +15%.

4 Conclusion

An experimental study, using a Taguchi experimental design for measuring cost effectiveness, of the HCM refrigerant flow in adiabatic capillary tubes with different capillary tube lengths and diameters was performed. The inlet conditions and tube geometry were selected and the mass flow rates of the refrigerant were measured in accordance with a statistical design analysis. A generalized correlation to predict the refrigerant mass flow rate through the tube was derived based on the Buckingham Pi theorem from the measured data. The developed correlations were in good agreement with the measured HCM data of the present study with an average and standard deviation of -0.14% and 11.77% respectively. Further comparison of the developed correlation with measured HCF data of previous investigators from the literature showed that this correlation may not work well with HFC refrigerants. Thus, the correlation can be applied by designers of capillary tubes using HCs and their mixtures as refrigerant.

Acknowledgements

The present study was financially assisted by the research university grant (RUG) program: Tier 2 Cost Centre Code: QJ130000.7124.01J85, Universiti Teknologi, Malaysia. The financial support of the Educational Trust Fund (ETF), Nigeria is also acknowledged.

References

- [1] Ibrahim, D., *Refrigeration Systems and Application*, John Wiley & Sons Ltd., West Sussex, United Kingdom, 2003.
- [2] Wongwises, S., Kaew-On, J., Nilpueng, K. & Chingulpitak, S., *An Experimental Study of the Flow Phenomena of R134a Flowing through a Capillary Tube*, Proceedings of the 8th International Conference on Nanochannels, Microchannels and Minichannels, Quebec, Canada, pp. 1475-1479, 2011.

- [3] Shodiya, S., Azhar, A.A. & Darus, A.N., *Improved Refrigerant Characteristics Flow Predictions in Adiabatic Capillary Tube*, Research Journal of Applied Sciences, Engineering and Technology, **4**(13), pp. 1922-1927, 2012.
- [4] Kumar, R., Khan, M.K. & Sahoo, P.K., *An Experimental Study of the Flow of R-134a Inside An Adiabatic Spirally Coiled Capillary Tube*. International Journal of Refrigeration, **31**(6), pp. 970-978, 2008.
- [5] Kumar, R., Mittal, M.K. & Gupta, A., *An Experimental Study of The Flow of R-407C in an Adiabatic Helical Capillary Tube*. International Journal of Refrigeration, **33**(4), pp. 840-847, 2010.
- [6] Shodiya, S., Azhar, A.A., Henry, N. & Darus, A.N., *New Empirical Correlations for Sizing Adiabatic Capillary Tubes in Refrigeration Systems*, American Institute of Physics Conference Proceedings, **1440** (1), pp. 341-355, 2012.
- [7] UNEP, *The 1987 Montreal Protocol on Substances that Deplete the Ozone Layer*, United Nations Environment Programme (UNEP), 1987.
- [8] Corberan, J.M., Seguradoa, J., Colbourneb, D. & Gonzálvez, J., *Review of Standards for the Use of Hydrocarbon Refrigerants in A/C, Heat Pump and Refrigeration Equipment*, International Journal of Refrigeration, **31**(4), pp. 748-756, 2008.
- [9] Fatouh, M. & El Kafafy, M., *Assessment of Propane/Commercial Butane Mixtures as Possible Alternatives to R134a in Domestic Refrigerators*, Energy Conversion and Management, **47**(15-16), pp. 2644-2658, 2006.
- [10] Wongwises, S., Kamboon, A. & Orachon, B., *Experimental Investigation of Hydrocarbon Mixtures to Replace HFC-134a in an Automotive Air Conditioning System*, Energy Conversion and Management, **47**(11-12), pp. 1644-1659, 2006.
- [11] Nasution, H., *Energy Efficiency on Split-Type Air Conditioning System Using Hydrocarbon Mixtures as Drop-In Replacement for R-22*, The 3rd International Conference on Construction Industry Padang–Indonesia, pp. 1-10, 2012.
- [12] Fatouh, M., *Theoretical Investigation of Adiabatic Capillary Tubes Working with Propane/N-Butane/Iso-Butane Blends*, Energy Conversion and Management, **48**(4), pp. 1338-1348, 2007.
- [13] Montgomery, D.C., *Design and Analysis of Experiments*, John Wiley and Sons, Inc., United State of America, 2005.
- [14] Boldstad, M.M. & Jordan, R.C., *Theory and Use of the Capillary Tube Expansion Device*, Refrigerating Engineering, **56**(12), pp. 519-523, 1948.
- [15] Wolf, A., Bittle, R.R. & Pate, M.B., *Adiabatic Capillary Tube Performance with Alternative Refrigerants*, ASHRAE Research Project, RP-762, 1995.
- [16] Kim, S., Kim, M. & Ro, S., *Experimental Investigation of the Performance of R22, R407C and R410A in Several Capillary Tubes for*

- Air-Conditioners*, International Journal of Refrigeration, **25**(5), pp. 521-531, 2002.
- [17] Jabaraj, D.B., Vettri Kathirvel, A. & Mohan Lal, D., *Flow Characteristics of HFC407C/HC600a/HC290 Refrigerant Mixture in Adiabatic Capillary Tubes*, Applied Thermal Engineering, **26**(14-15), pp. 1621-1628, 2006.
- [18] Khan, M.K., Kumar, R. & Sahoo, P.K. *Experimental and Numerical Investigation of R-134a Flow through a Lateral Type Diabatic Capillary Tube*, American Society of Heating, Refrigerating and Air-Conditioning Engineers, **14**(6), pp. 871-904, 2008.
- [19] Melo, C., Ferreira, R.T.S., Neto, C.B., Goncalves, J.M. & Mezavila, M.M., *An Experimental Analysis of Adiabatic Capillary Tubes*, Applied Thermal Engineering, **19**(6), pp. 669-684, 1999.